

**POWER-LCC Module
for LCC®/OpenLCB™
SPROG DCC Ltd**

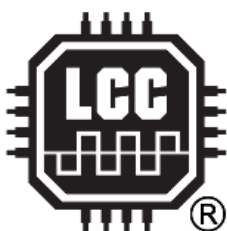

Copyright © October 2024 SPROG DCC Ltd.

This document may be distributed it under the terms of Creative Commons Attribution License (<http://creativecommons.org/licenses/by/3.0/>), version 3.0 or later.

Contact:

SPROG DCC Ltd
Anvil House, Butt Lane
Harbury
Leamington Spa CV33 9JL
United Kingdom
<https://www.sprog-dcc.co.uk>
sprog@sprog-dcc.co.uk

Date	Revision	Comments
January 2024	1	Created
February 2024	1.1	Added isolation diode issue
October 2024	1.2	Update module photos
November 2024	1.3	Added LED and power identification

Unless otherwise notes references in this document to LCC apply equally to OpenLCB, and vice-versa.

LCC® is a registered trademark of the NMRA

OpenLCB™ is a trademark of the OpenLCB Group

Contents

1	Introduction.....	4
2	Power Connections.....	4
3	Connecting the POWER-LCC to the network.....	4
4	LED Indicators.....	5
5	Known Issues.....	5
5.1	Power Isolation.....	5
6	Links.....	5

1 Introduction

The power LCC allows power to be supplied to an LCC network. It is designed to be used with an external 12V 1 Amp PSU (Power Supply Unit).

2 Power Connections

Either of the two power input connectors may be used to supply power to the LCC network: A DC barrel connector suitable for wall warts with a centre-positive plug; A two-way pluggable terminal block.

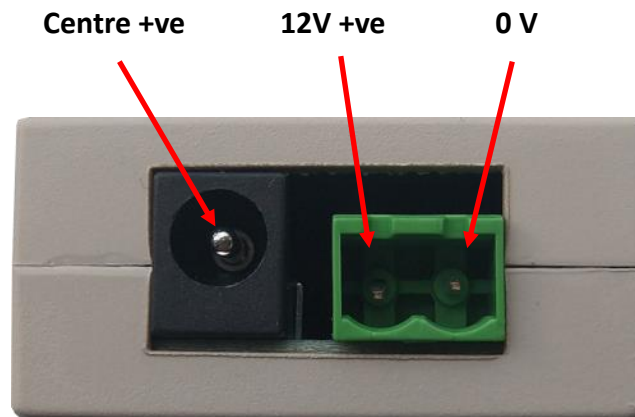

3 Connecting the POWER-LCC to the network

The two RJ-45 connectors allow the LCC network to be passed through the USB-LCC whilst supplying power to the network.

The power from the PSU is split into two 500 mA fused supplies, one to each LCC network connector. In a larger network, multiple POWER-LCC may be used to satisfy the power requirements of all the nodes in 500 mA segments.

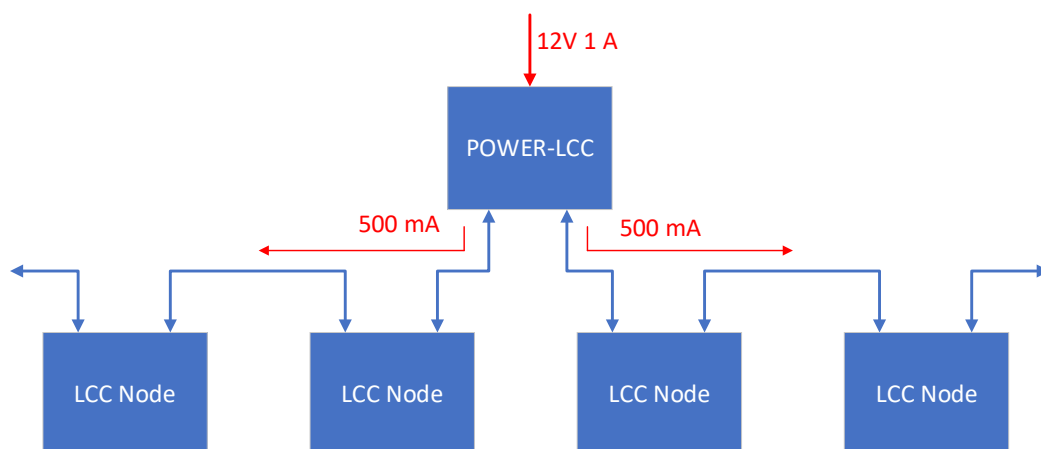

Status LEDs show when power is applied to each segment.

Some LCC nodes may need auxiliary power supplies for high-power loads. Consult the manufacturers' documentation for details.

4 LED Indicators

A number of LEDs are provided to show power and network status

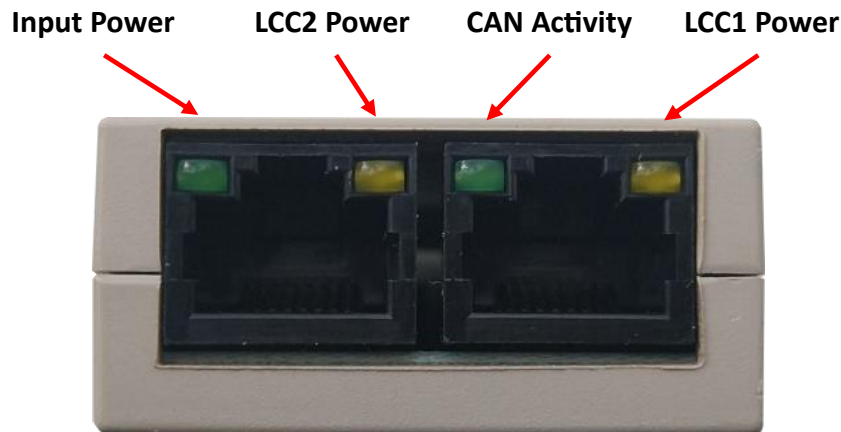

5 Known Issues

5.1 Power Isolation

On older, uncased, modules there is a single isolation diode between the PSU input and the power on the two RJ45 LCC network connectors. If more than one such POWER-LCC is used on a network, issues may be encountered as the power islands created are not isolated.

This is fixed on the new enclosed version of hardware, as described in this document.

6 Links

SPROG DCC Ltd website <https://www.sprog-dcc.co.uk> For all our products and support.

SPROG DCC Ltd Official YouTube Channel <https://www.youtube.com/@sprogdcc>

OpenLCB group <https://openlcb.org> The group behind the OpenLCB/LCC standards.

NMRA LCC standards page <https://www.nmra.org/lcc> The LCC standards adopted by the NMRA.

OpenLCB discussion group <https://groups.io/g/openlcb/topics> Discussion of OpenLCB topics, more developer focussed.

The NMRA's LCC user group <https://groups.io/g/layoutcommandcontrol/topics> a good starting point for asking questions of other LCC users.

Book: Introduction to Layout Command Control <https://www.amazon.co.uk/Introduction-Layout-Command-Control-Practical/dp/0988825902> focussed on RR-Cirkit's products but the concepts are applicable to any LCC hardware.